

Homework 4

EECS/BioE/MechE C106A/206A
Introduction to Robotics

Due: September 27, 2022

Note: This homework assignment is due two days before the midterm. As such, we will not be allowing late submissions at all (including those using slip days), since we will release solutions as soon as the assignment is due to give you a chance to look over them before the exam.

Problem 1. Inverse Kinematics for 3DOF Manipulators

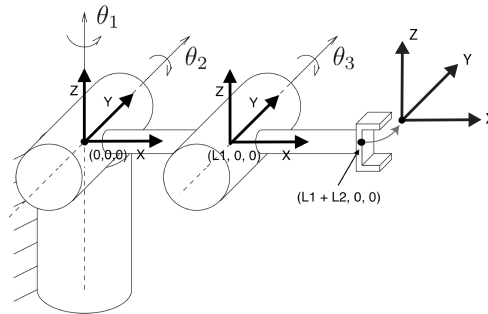

Figure 1: A robot with 3 revolute joints.

The above figure shows a 3DOF manipulator in its initial configuration with 3 revolute joints. Assume $L_1 > L_2$.

- Describe the reachable workspace of the robot.
- Use Paden-Kahan subproblems to solve the inverse kinematics problem for this manipulator. You do not need to write out the details of how you would find the exact solution for each subproblem. It suffices to indicate how you would break up the inverse kinematics problem into PK subproblems. Remember to clearly indicate which subproblem you are using in each step, and what conveniently chosen points you are using to make your reductions.
- Indicate the maximum number of possible inverse kinematics solutions.

Problem 2. Inverse Kinematics for 6DOF Manipulators

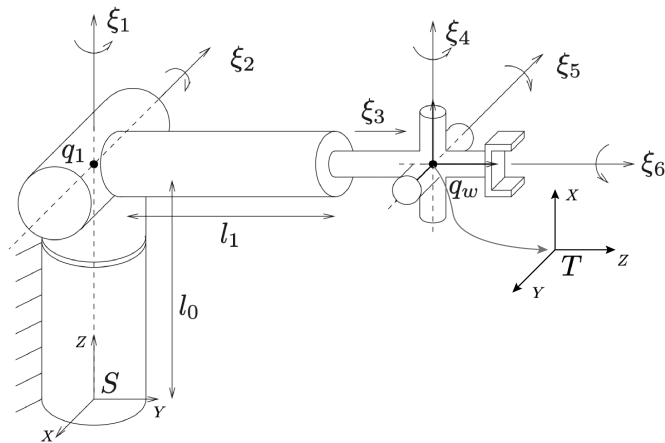

Figure 2: An idealized version of the Stanford arm.

The above figure shows the 6DOF Stanford arm in its initial configuration, with 5 revolute joints and one prismatic joint (joint 3). You may assume that in the initial configuration, q_w is a distance l_1 away from q_1 . Further assume that $0 \leq \theta_3 \leq d_{max}$.

- Describe the reachable workspace and the dexterous workspace of the robot.
- Use Paden-Kahan subproblems to solve the inverse kinematics problem for this manipulator. You do not need to write out the details of how you would find the exact solution for each subproblem. It suffices to indicate how you would break up the inverse kinematics problem into PK subproblems. Remember to clearly indicate which subproblem you are using in each step, and what conveniently chosen points you are using to make your reductions.
- Indicate the maximum number of possible inverse kinematics solutions.